

Æthelmearc Policies of the Marshal of Fence

May 19, 2018

I. General Requirements:

A. Minimum Age - The minimum age for training and authorization in rapier combat is 14.

i. When fighters under the age of 18 undertake training and authorization, the Kingdom Rapier Marshal (or his designated representatives) shall ensure that the minor's parent or legal guardian has observed rapier combat, is aware of the risk of injury inherent in this martial art, and has signed the "informed consent to participate in SCA combat", which explicitly acknowledges the above.

ii. When the parents/legal guardian are not with the minor, there must be a minor's medical authorization filled out and signed. Copies of this form should be in the possession of the named minor; at least one adult named in the document and present at the event; and the parent or guardian executing the Medical Authorization. This form should be shown to the marshal in charge of the activity whenever the parent/guardian is not present.

iii. Minors engaging in combat with adults shall be marked in the following manner: yellow diamond(s) no larger than 1 inch (24 mm) but no smaller than 0.5 inch (12.7 mm) on the cuff of the glove of their dominant weapon hand.

B. All fighters and marshals are responsible for understanding and abiding by these Rules for Æthelmearc Rapier Combat, the SCA Rules of the List, and the Corporate Rules for Rapier Combat in the SCA.

C. Prior to every combat, tournament or practice, all combatants shall insure that their equipment is safe, in good working order, and has been inspected by a warranted marshal of Æthelmearc.

II. Armor Requirements

A. No skin shall show anywhere on the fencer's body regardless of the position or stance of the fencer. There shall be sufficient overlap (3 inches of overlap recommended) between separate pieces of armor that the required protection for that body area is preserved. Corporate standard definitions for armor are as follows:

- a. Abrasion-resistant material: material that will withstand normal combat stresses (such as being snagged by an unbroken blade) without tearing. Examples include broadcloth, a layer of heavy poplin cloth (35% cotton, 65% polyester), sweat pants, opaque cotton, and poly-cotton. Nylon pantyhose, spandex, and cotton gauze are examples of unacceptable materials.
 - b. Puncture-resistant material: any fabric or combination of fabrics that will withstand puncture. Examples include 4-ounce (2 mm) leather, four layers of heavy poplin cloth, ballistic nylon rated to at least 550 Newtons, and commercial fencing clothing rated to at least 550 Newtons. Kevlar is not an acceptable material as it degrades rapidly.
 - c. Rigid Material: puncture-resistant material that will not significantly flex, spread apart, or deform under pressure of 12 Kg applied by a standard mask tester, repeatedly to any single point. Examples of rigid material are - 22-gauge stainless steel (0.8 mm); 20-gauge mild steel (1.0 mm); 16-gauge aluminum, copper, or brass (1.6 mm); one layer of hardened heavy leather (8 ounce, 4 mm).
- B. Fencing Mask - The front and top of the head must be covered by rigid material to below the jaw line and behind the ears. Standard 12 kg fencing masks meet this standard. Fencing helmets meeting this standard are also acceptable and shall be approved on a case-by-case basis. The face must be covered by either 12-kilogram mesh (e.g., a standard fencing mask) or perforated metal which meets the definition of rigid material and has holes no larger than 1/8 inch (3 mm) in diameter and a minimum offset of 3/16 inch (5 mm). Masks and helmets must be secured to the fighter so that they cannot be easily removed or dislodged during combat. The combination of a snug fit and the spring-tongue in a conventional fencing mask is not sufficient by itself to secure the mask to the fighter.
- a. All parts of a fencing mask or rapier helmet that might cause injurious contact with the wearer's head shall be padded or shall be suspended in such a way as to prevent contact with the wearer during combat. Either method should ensure a snug fit with minimal shifting of the mask or helmet on the fighter's head during normal fighting and upon impact. There shall be NO major internal projections; minor projections of necessary structural components shall be padded. All metal shall be free of sharp edges.
 - i. The interior of fencing masks must have a minimum of .25 inches (6.35mm) open-cell foam or equivalent resilient padding to create separation between the mask and the wearer. Modern fencing masks (e.g. FIE and USFA type masks) in good working order meet this requirement without additional padding.

- ii. For rapier helms that utilize a suspension system which does not, on its own, prevent contact between the wearer and any rigid part of the helm, additional padding must be present. This padding must consist of at least .25 inches (6.35mm) open-cell foam or equivalent resilient material.
- iii. Rapier helms without a suspension system and which rely on foam must use a minimum of .25 inches (6.35mm) closed-cell foam or equivalent resilient padding which provides progressive resistance to create separation between the hard outer shell of the helm and the wearer.

C. Head and Throat –

- a. The rest of the head and neck must be covered by at least puncture resistant material. However, combatants are strongly encouraged to wear heavier protection than this minimum requirement.
- b. Additional throat protection is required. This shall consist of rigid material as defined (gorgets made of metal are strongly encouraged) covering the entire throat and shall be backed by either puncture resistant material (such as a hood), one quarter inch (1/4 inch / 6 mm) of open-cell foam, or their equivalents. Gorgets worn over a hood or other substantial fabric padding will be considered to meet this requirement. The cervical vertebrae shall also be protected by rigid material provided by some combination of gorget, helm, and/or hood insert.

D. Torso and Arm Armor - Puncture resistant armor shall cover the body from the top of the shoulder to the base of the groin and the underarm area extending down the underside of the arm one-third the distance to the elbow. The rest of the arm must be covered with abrasion resistant material.

E. Gloves - Gloves made of abrasion resistant material must overlap the wrist openings of the sleeves by at least 3 inches and cover any cuff opening. If gloves designed for electric equipment are used, the openings for wires must be secured shut.

F. Groin/Breast Armor - Male fencers shall wear a cup (rigid material) underneath the lower extremity armor. Female fencers must ensure that their groin area is covered by puncture resistant material. Additional breast armor for females is left to individual discretion; however, female fencers are strongly encouraged to employ additional breast protection.

G. Lower Extremity Armor - All portions of the lower extremities must be covered with at least abrasion resistant material. If skin can be seen through the material,

the material is too thin. Footwear must completely enclose the foot with a minimum of abrasion resistant material.

- H. Armor Testing – Armor shall be tested and repeated every two years afterwards; however, armor may be retested at any point if a marshal feels that there is something amiss. Acceptable tests are as follows:
- a. Cloth or garment manufacturer’s commercial certification that a fabric is rated to 550 Newtons. Documentation must be available at time of inspection.
 - b. Use of a 550 Newton punch test device, manufactured by sources approved by the Deputy Society Marshal for Rapier Combat and used in accordance with the instructions for such a device.
 - c. Use of a drop test device which delivers a force, on dropping, of 1.5 joules to the fabric sample via a dull, flat 5/32 inch (4mm) metal rod. Details for constructing and using an approved device of this sort may be found in Appendix 3 of the Corporate Rules for Rapier Combat.
 - d. For masks: Marshals have the right and responsibility to refuse any mask that they deem to be in danger of failing to protect against a hard thrust with an epee. Upon the wearer's request, a mask may be punch-tested with a commercial mask tester if this equipment is available. Marshals cannot require a punch test. A good field test if a punch tester is not available, is to push on the mesh with a thumb. If the mesh shows any flex, the mask is not strong enough.

III. Weapons Specifications

A. Rapiers

- a. Blades will fall under the classifications of Light Rapier and Heavy Rapier.
 - i. Light Rapier blades are limited to commercial foil and epee blades.
 - ii. Heavy Rapier blades are defined by those blades described in the Society Rapier Marshal list of approved rapier blades (Rapier Combat Handbook Appendix 5 – Blade Types and Conventions.)
- b. The Society Rapier Policies define a single handed rapier as having a blade between 18 and 48 inches long with a hilt no longer than 10 inches in length. A two handed rapier is defined as having a blade between 30 and 48 inches in length with a hilt at least 10 inches long but not exceeding one third of the length of the blade. Single hand rapier and two

handed rapiers are considered to be in the same class and may be used against each other.

- c. Swords of any kind will not exceed 4 lbs. in total weight, 60 inches in total length, and may have a hilt (including pommel) of no longer than 18 inches. For safety as well as ease of control, all weapons, especially single handed weapons, are recommended to be much shorter and lighter. Any exceptions to this rule must be approved by the Kingdom Rapier Marshal.
- d. Any blade of a given class may only be used against weapons of that class, but NOT against blades of another class (i.e. Light Rapiers cannot be used against Heavy Rapiers). Daggers may be used against rapiers of either type.
- e. Light Rapier points must be capped with standard plastic or rubber fencing tips and must be taped with tape that contrasts in color with the blade and the tip. The tape must not cover the tip.
- f. Foil, epee, and sabre guards are permitted on Light Rapiers. Guards with openings large enough to admit a standard, capped Light Rapier point must be blocked with rigid material. Quillons can be no longer than 12 inches from tip to tip. The ends must be blunted and all edges rounded. Quillons that may trap and/or break a blade are cause for prohibiting the use of the blade. Orthopedic (or "Pistol") grips will not be used unless the fighter has approval for medical reasons, supported by documentation from their health care provider.
- g. Heavy Rapier blades are defined as those blades described in the Society Rapier Marshal list of approved rapier blades.
- h. Before placing a tip on the blade, the point of a Heavy Rapier blade that was not manufactured with a safety tip shall be filed or cut down flat. Any sharp edges shall then be filed smooth.
- i. The tip of a Heavy Rapier blade shall be covered in one of the following ways:
 - i. Rubber archery blunts (bird blunts): Blades using these tips must either be manufactured with a permanent perpendicular safety tip (i.e. a "nail head" or "anvil head") created as the tip of the blade at time of initial forging or be covered with a metal casing, washer, or nut.
 - ii. Darkwood Armory tips: These do not require a metal casing or other barrier provided that the sword tip meets the requirements in (3.h) above.

- iii. 3D-printed tips: These must be designed and printed according to the specifications given in Appendix 1. Blades using these tips must be covered with a metal casing, washer, or nut regardless of blade construction.
- iv. Other equivalent tips may be approved by the KMoF on a case-by-case basis.
- v. Standard foil and epee tips are not to be used as Heavy Rapier tips.
- j. The rubber tip of the Heavy Rapier must be taped to the blade itself with colored duct tape or woven cloth tape in a color that distinctly contrasts with the blade and the tip. Tool dip is not an acceptable substitute. The tape shall not cover the end of the rubber tip but shall leave enough showing that a marshal would be able to see if the rubber tip is wearing through.
- k. Open guards and hilts may be used with Heavy Rapiers so long as they present no sharp edges or protrusions that would present a hazard to the fencer or an opponent.
- l. All rapier weapons shall be fought as light two-edged weapons with a point.
- m. Marshals shall disqualify weapons that are in danger of breaking.
- n. All blades must be manufactured by a commercial supplier or an artisan approved by the Society Deputy Marshal for Rapier Combat and the Kingdom Marshal of Fence.
- o. Blades will not be altered in any way that would significantly alter their temper, flexibility, or durability.
- p. All blades must be able to pass a flexibility test as follows: Hold the weapon parallel to the ground, supporting the handle against a table or bench if necessary. Hang a 6-ounce weight (170 grams) just behind the tip. A dagger blade (up to 18-inch blade length) that flexes visibly (more than 1/2 inch / 12 mm) is sufficiently flexible. A rapier blade (greater than 18 inches) must flex a minimum of 1 inch (24 mm).

B. Two Handed Rapiers

- a. Any full length sword (18" or longer blade) with handle length including pommel greater than 10" shall be considered as a two handed sword and may only be used in heavy rapier with a 2-Handed Authorization.

- b. A two handed sword with handle length, including pommel, greater than 10” and less than 14”, used in heavy rapier, may be used in one hand or in two hands.
 - i. Such weapons may only be used as a single weapon, with a dagger, or with a defensive secondary in the other hand.
 - ii. Such weapons may NOT be used with another full length sword as part of a Case of Rapiers.
- c. A two handed sword with handle length, including pommel, greater than 14”, used in heavy rapier, must have two hands on the weapon at all times.
 - i. If a hand/arm is disabled while playing in a melee, the wielder is considered disarmed.
 - ii. If a hand/arm is disabled while playing in a tournament, the wielder is defeated. The wielder’s opponent may allow a switch to a one-handed weapon.

C. Daggers

- a. The maximum allowable length for a dagger is 25 inches from pommel to tip.
- b. Society Rapier Policy defines a dagger blade as being 18 inches or less in length.
- c. Guards, grips, and quillons shall follow the specifications for the class of blade with which they are being used.
- d. Standard thrusting daggers shall be commercial dagger blades as approved by the SRM, which will be capped as rapiers are (See III.A.2 above).
- e. Daggers score in the same manner as rapiers.
- f. Daggers may be used against both Heavy Rapiers and Light Rapiers.

D. Spears, Pikes, or Pole Arms

- a. All weapons longer than 60” overall, or with a handle longer than 18” are defined as belonging to this category of weapon and are not permitted in any Aethelmearc fencing activity.

E. Parrying Objects

- a. Striking any part of the body with any parrying object is strictly illegal.
- b. Sharp points, edges, or corners are not allowed anywhere on any equipment.
- c. Devices that predictably or repeatedly cause entangling are not allowed.

i. Bucklers

1. The allowable maximum area for a buckler used in tournament combat is 315 square inches (20 inch diameter circle). There is no size restriction for bucklers and shields used in melee combat other than they must be wielded with one hand and are not intended to rest on the ground. This does not prevent a fencer from resting a legal buckler or shield on the ground during combat. Organizers running warlord tourneys, two on two tourneys and similar events may use the 315 sq. inch restriction at their discretion.
2. Bucklers shall be constructed of lightweight rigid material.
3. Buckler edges shall be covered to prevent splintering and may not be jagged or rough.
4. Other Parrying Devices: Virtually any object may be used as a parry item, provided that the object poses no threat to the safety of the combatants and will not trap and/or break a blade. Marshal discretion regarding the safety of the parry item is the deciding factor as to whether or not it will be permitted into the list.

ii. Cloaks

1. Cloak size, shape, and weight are left to the discretion of the user.
2. Soft hem weights such as rope, rolled fabric or leather are permitted. Rigid weights such as bars, rods, chains or strips of metal are prohibited.
3. Cloaks will be allowed to take multiple hits without being considered to have sustained ruinous damage to the fabric; however, if the marshal sees things getting out of hand, he or she may step in and advise the fencer that the cloak is no longer useful. A thrust or cut will penetrate a cloak and do damage to the fencer.

F. Projectile Weapons:

- a. Rubber band guns (RBGs), weapons firing a flexible round (rubber bands or surgical tubing), may be used in rapier melee combat only. Their use in melee will be at the discretion of the marshal-in-charge and may be subject to additional restrictions.
- b. The use of any projectile weapon is forbidden within formal rapier tournament lists (single combat) or in any situation where spectators cannot be separated from the potential line of fire by more than the effective range of the projectile weapons to be used.
- c. RBGs should mimic the appearance of period firearms, shall be constructed of wood and/or light weight metals, and must conform to the rules restricting the construction of rigid parry items. Gun barrels large enough to admit the tipped end of a blade must be plugged. All RBGs and rounds must be inspected before use.
- d. Ammunition must be of entirely flexible material (i.e. no washers) except for the plastic connector used to hold the round together, which must be covered either by the round itself or by shrink tube in a manner that prevents the plastic from striking the target of the round.
- e. All hits from RBGs count as a thrust to the body part struck. If the round strikes a weapon or parrying device, both that weapon and the hand holding it are countered as lost. Accidental discharges of the gun count as per normal firing of the weapon.
- f. RBG bullets penetrate bucklers and soft non-rigid devices in a straight line. Active marshalling shall be used to aid in the acknowledgement of hits.
- g. It shall be understood that fencing helms, large bucklers and heavy cloaks may impede accurate acknowledgement of RBG bullets.
- h. Due to the risk of being hit by stray rounds, marshals supervising RBG melees will wear eye protection such as protective goggles or their fencing mask so long as vision is unimpaired (i.e. can you still see a broken weapon) and they can be clearly distinguished from the combatants.

IV. Weapons Forms

- A. Rapier - The form shall consist of a single rapier. The fencer should use the empty hand for defense.
- B. Rapier and parrying object.
- C. Rapier and dagger.

- D. Case of rapiers: The form shall consist of two rapiers.
 - E. Two Handed Rapier: This form shall consist of any deliberate use of two hands on a sword.
- V. Combat Conventions
- A. Fencing rules:
 - a. All fencers will behave in an honorable and chivalrous manner. Ill-tempered behavior shall not be tolerated. “Rules Lawyering” or “gaming” the rules, violates this rule.
 - b. The calibration standard for the Kingdom of Aelthelmearc shall be the lightest touch that you can reasonably expect your opponent to feel.
 - c. Any blow that strikes a mask, helm, or gorget shall be counted as though it struck flesh. Consistent, excessive calibration shall be grounds for revocation or denial of authorization.
 - i. All fencers are considered to be wearing cotton, linen, or wool street clothing of the period that these rules are intended to simulate. Skirts are to be no longer than ankle length and not entangle the fencer's normal movement. Corseting, bum rolls, or anything that drastically changes the form of the body is prohibited. Clothing which prevents the wearer from accurately calling blows is prohibited.
 - ii. It is the responsibility of each fencer to determine what weapons his or her opponent is using and to resolve any questions about said weapons before combat.
 - iii. Any portion of the body is a legal target.
 - iv. Any charging, running, hopping, or other attack where the fencer cannot immediately cease movement when a hold is called is strictly prohibited (example: a fleche).
 - v. Draw cuts, push cuts, and tip cuts are all considered to be valid cuts. For a cut to be counted, there must be at least 6 inches (15 cm) of movement with the blade or travel of the tip against the target. Cuts that move across the entire width of a limb or the throat will count even if they are not 6 inches long. Whipping, hacking, and modern sabre cuts are prohibited. With Heavy

Rapier blades, cuts with the flat of the blade will not be counted as valid.

- vi. Wrestling, grappling, and kicking an opponent are prohibited.
- vii. Striking with any portion of the weapon other than the blade is prohibited.
- viii. Combat between fencing weapons and SCA heavy list weapons is prohibited.
- ix. A fencer is considered armed so long as one offensive weapon is retained.
- x. Upon hearing the call of "HOLD" all fighting shall immediately stop. The fencers shall freeze, check their immediate area for hazards, and then assume a non-threatening position with their weapons pointed away from everyone in their vicinity. Unless instructed otherwise, fencers are to remain in the same location on the field.
- xi. Hold will not be called for dropped weapons unless it becomes a safety issue. A fencer who disarms his or her opponent will have the option of allowing the opponent to retrieve his or weapon or forcing the opponent to yield. A fencer who has been disarmed must abide by his or her opponent's decision.
- xii. Parries with the empty hand while using single rapier are permitted and are not considered as wounding so long as the blade is not drawn, pushed, or thrust against the hand. Use of the open hand to push aside an opponent's weapon hand is also allowed so long as the opponent is not grasped and contact only occurs on the hand just below the bell.
- xiii. Entrapping, "catching," or "placing" an opponent's weapon or parrying device in a position in which it is irretrievable through the use of the hand or any other object is prohibited.
- xiv. Heavy Rapier, light blade grasping is permitted with the consent of both combatants for a maximum of 5 seconds. Torsion or movement of the blade within the grasp of the hand will result in loss of the hand.
- xv. All fencing is to be done in the round.
- xvi. No object may be thrown or tossed during the course of a bout.

- xvii. At the end of every tournament bout it is the list marshal's duty to ask each fencer if he/she is satisfied with the conduct of the bout.

B. Qualifications for Authorization

- a. The fencer will have clear understanding of the rules and armor requirements of SCA fencing and particularly of the SCA period fencing rules for Æthelmearc.
- b. Fencer poses no unnecessary risk of injury either to his opponent or to himself.
- c. The fencer can define and demonstrate some defensive capability including the use of the off-hand for defense.
- d. The fencer can define and demonstrate some offensive capability other than just a direct attack.
- e. All fencers must authorize in single Heavy Rapier as their first weapons form. After that, authorizations for other weapons forms may be attempted in any order.
 - 1. Light Rapier authorization will consist of single light rapier, after the first authorization is obtained, the fencer may fence light rapier in any form in which they are authorized in heavy rapier.
 - 2. Two warranted Æthelmearc rapier marshals must be present to qualify a fencer, one of which must be from a group other the fencer's home group. At least one authorizing marshal must possess the authorization being tested. Exceptions to this rule may only be made by the Kingdom Rapier Marshal or by a designated representative of the Kingdom Rapier Marshal.
- f. Separate qualifications are necessary for: Single Light Rapier, Single Heavy Rapier, Rapier and Parrying Object, Rapier & Dagger, Case of Rapiers, and Two Handed Rapier.
- g. In order to authorize in the use of Heavy Rapier blades, a fencer must demonstrate:
 - 1. A thorough understanding of the rules of fence of the SCA and of the Kingdom of Æthelmearc including all specific rules relating to Heavy Rapier use.

2. The ability to use Heavy Rapier blades safely and competently so as not to present a danger to one's self or one's opponent.
3. The ability to define and demonstrate adequate offensive and defensive capability.
4. The ability to demonstrate acceptable calibration both in the giving and receiving of blows.

C. Scoring

- i. Before each round in a tournament, calibration between unfamiliar opponents will be mandatory.
- ii. A kill is considered to be a thrust or cut to the torso, head, neck, groin (to one hand's width down the inside of the leg), and armpit (to one hand's width down the inside of the arm).
- iii. An arm, hand, leg, or foot is rendered unusable after a thrust or cut to it. If an arm or hand is lost, it cannot be used. If a leg or foot is lost, the combatant must kneel or sit. A hip or buttock is part of the leg on the same side. The combatant may not rise up or use the muscles of the injured leg but may pull himself along using only arms or hands.
- iv. Lost limbs may not be used in a defensive manner in any way, shape, or form. Blows that strike a lost limb that would have contacted the body are to be counted as having struck the body.
- v. Any blow may be counted by the recipient as more damaging than technically required if it in his or her opinion would have caused a disabling wound. No blow may be counted as less effective than the above rules require.

VI. Marshaling

- A. The Kingdom Marshallate shall institute such standards and procedures for authorizing participation in fencing at SCA events and for the warranting of fencing marshals as shall be deemed necessary.
- B. Active marshaling shall be used to aid in acknowledgement of hits.

- C. Marshals shall be thoroughly versed and current on the SCA period fencing rules of the Society and of Æthelmearc and shall practice and enforce such rules during any SCA fencing activity.
- D. Marshals shall be specifically trained and warranted as per the rules of fence of the Kingdom of Æthelmearc and shall be qualified in a minimum of three weapons forms.
- E. The Kingdom Marshal retains the sole authority for inspecting and allowing the use of materials other than those specified in these rules.
- F. Marshals shall thoroughly inspect and test weapons and equipment for compliance with SCA and Kingdom standards prior to allowing their use. Weapons and armor inspection must occur at every practice and every tournament.
- G. Before tournaments, marshals must mark in a distinctive fashion weapons that either pass or fail inspection. Note that marshals may not destroy or confiscate a weapon that fails inspection.
- H. All bouts shall have at least one warranted fencing marshal present and attentive.
- I. The marshals watching a bout have absolute say on a fencer's conduct on the field and may summarily eject any fencer who is guilty of misconduct or unsafe behavior.
- J. At the conclusion of each bout, the marshal in charge will ask the competitors if they are satisfied with the conduct and outcome of the bout. Any questions concerning the bout will be addressed immediately. If necessary; the Marshal in Charge may declare an outcome.
- K. As representatives of the SCA, all fencing marshals are required to maintain current paid membership in the SCA.
 - a. Marshal warrants shall be renewed annually on the anniversary date of membership renewal.
 - b. Experimentation Procedures
 - i. Before any new weapon or technique can be used in Society Rapier Combat, a test plan must be submitted to and approved by the Kingdom Marshal of Fence. This plan shall describe: The new weapon or technique, specifics of materials used and construction of the weapon (as appropriate), and the proposed uses of the new weapon or technique. In the case of new blade

types, a sample of the new blade-type must be submitted to the Deputy Society Marshal for Rapier Combat for direct evaluation.

- ii. It is the prerogative of the Kingdom Rapier Marshal, subject to approval of the Kingdom Earl Marshal and the Deputy Society Marshal for Rapier Combat, to allow testing of new weapons or techniques within a kingdom. Testing will only occur for a set period of time and may be subject to certain additional restrictions.
- iii. Testing means the weapon or technique may be used at fighter practice, tourneys, or in small melees under the supervision of the Kingdom Marshal of Fence or a specifically designated representative and only after all combatants and marshals have been informed the weapon or technique is not SCA approved. All participating combatants and marshals must consent to the use of the weapon or technique before combat begins. If the Marshal in Charge objects to the test, it may not be performed under his/her jurisdiction
- iv. At regular intervals the persons designated as "testers" must report to the Kingdom Marshal of Fence with a test summary to include when and where testing occurred, any equipment failure associated with the tests, a list of any injuries that resulted from the use of the weapon or technique, and any concerns from fighters and marshals arising from the testing. The Kingdom Marshal of Fence must provide quarterly updates to the Kingdom Earl Marshal.

VII. Melee Rules. A melee is defined as any bout involving three or more fencers. The following rules are in addition to the rules for a standard list.

- A. In melees, fighters are engaged with all opponents immediately upon the call to lay on.
- B. At the call of lay on, all combatants in a line are considered to be engaged with all opponents in the opposing line.
- C. Fighters may only strike an opponent with any legal blow if they are within a 180-degree arc of the opponent's face (i.e. can see their eyes) and the opponent is aware of their presence. A fighter who approaches an opponent from behind shall not deliver a blow until he is within that frontal arc.
 1. A fencer may bind or foul an opponent's weapons without having recognition.

2. All defeated fencers must remove themselves from the melee field with their weapons visibly gripped by the blade or raised visibly overhead.
3. Death From Behind: Killing from behind is allowed unless it has been announced beforehand.
 - a. Death from behind is accomplished by a fighter by laying the rapier blade over the opponent's shoulder to at least one third of the blade while calling out "You are dead, my lord" (or other short courteous phrase) in a loud clear voice. Daggers may not be used to perform a Death From Behind attack.
 - b. Reaching around the neck is forbidden.
 - c. The opponent will be deemed "killed" from the instant the blade touches his shoulder and shall not attempt to spin, duck, or dodge away.
 - d. The attacker must come to a full stop behind the opponent before laying on his/her blade and must finish the aforementioned courteous phrase before moving on to include the Death From Behind action.
4. In special scenario melees additional restrictions may be imposed by the marshals as needed.
5. All participants in a Heavy Rapier melee should be authorized in Heavy Rapier. At the discretion of the marshal in charge, fencers who are not authorized in Heavy Rapier may be allowed to participate using a dagger only if the fencer is authorized in rapier and dagger in Light Rapier.

Appendix 1: Accepted standards for 3D printed blade tips

Custom tips printed on commercially-available home 3d printers have been determined to be acceptable so long as they meet the following standards:

- Printing material: TPU (NinjaFlex™)
- Fill Density: 100% (No air spaces)
- Dimensions:
 - Channel depth: the length of the blade which is inside the printed tip must be at least 30mm.
 - Pad Thickness: the minimum distance between the end of the metal insert and the striking surface of the tip must be at least 11mm

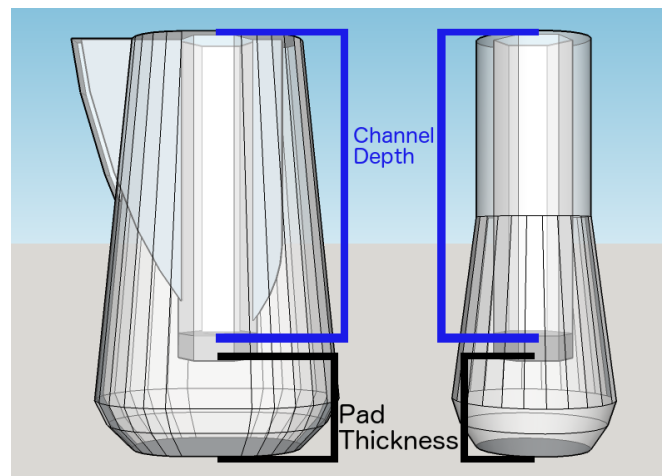

- Wall Thickness: the minimum distance between any part the blade and any side-wall of the printed tip must be at least 1mm (Walls may taper at the top, so long as the minimum thickness is maintained for at least the minimum channel depth.)

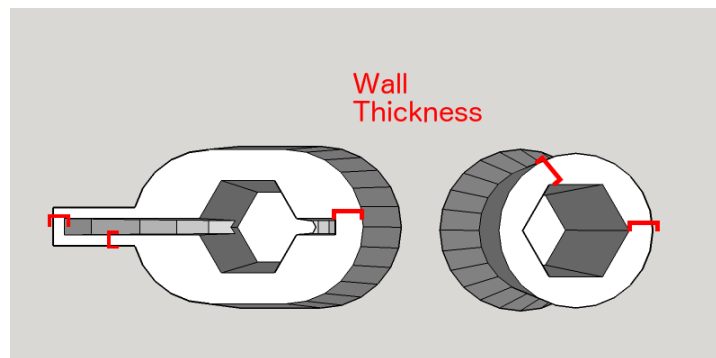

- Pad Diameter: The minimum width of the striking surface of the tip must be at least 14mm.

